

copyright © asupra editiei  
in limba romana:

SC Edilizia Tools SRL- distribuitor autorizat Ozgenc

www.utilaje-ozgenc.com

## OMRM 124



### MASINA AUTOMATA DE INFLETAT SURUBURI IN ARMATURA

UTILAJE  PERFORMANTE

#### Aplicatii / utilizari:

Pentru infletarea automata a suruburilor  
la fixarea ranforsarii in profilele de PVC

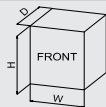
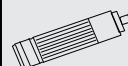
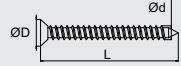
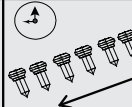

WZ 124	FEATURES											
	Bar	Air consumption (lt/min)	Kg	H (mm)	W (mm)	D (mm)	n max (RPM)	Kw max	ØD (mm)	Ød (mm)	L (mm)	Screw/min.
	6-8	10	102	1860	2400	620	2400	0,36	6,0-9,0	3,0-4,5	13,0-45,0	30

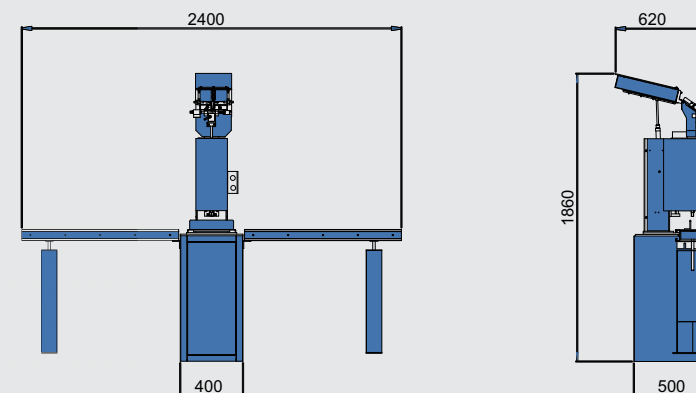

#### Caracteristici :

- Folosita la infletarea automata a suruburilor de fixare a armaturii in profilele de PVC
- Actionare in plan vertical cu o cursa utila de 145 mm
- Suport ajustabil pentru diferite tipuri de profile
- Actionarile sunt numai pneumatice (nu necesita racord la energia electrica)
- Control practic al echipamentului cu ajutorul unei pedale
- Sistem pneumatic de prindere a profilului
- Alimentare automata cu suruburi
- Permite ajustarea adancimii de infletare
- Inaltimea profilului poate varia intre 35 si 95 mm (distanța fata de masa suport)
- Ciclul de lucru pentru un surub auto-filetant standard de 3,9x19 mm de aprox. 2 sec.

#### Echipare standard:

- Bancuri cu role, 1 m stanga + 1 m dreapta

